



PRO COMP SUSPENSION, Inc. Chula Vista, CA USA

Ph:(619) 216-1444 ● Fax:(619) 216-1474 ● E-Mail: tech@explorerprocomp.com ● Website: www.explorerprocomp.com

INSTALLATION INSTRUCTIONS:

Part # 55076 TRANSFER CASE LOWERING KIT '76-'86 CJ-5, CJ-7 Jeep

⇒ **PLEASE READ ALL INSTRUCTIONS FROM START TO FINISH BEFORE YOU BEGIN INSTALLATION**

- 1) Place a suitable jack (preferably floor jack) under the transfer case cross member and support.
- 2) Remove and discard six (6) stock bolts and nuts and lower cross member one (1) inch.
- 3) Install lowering plates (2 per side) and start bolts and nuts.
- 4) Jack up cross member and tighten bolts to 35 ft./lbs.
- 5) Periodically inspect assemble for tightness.

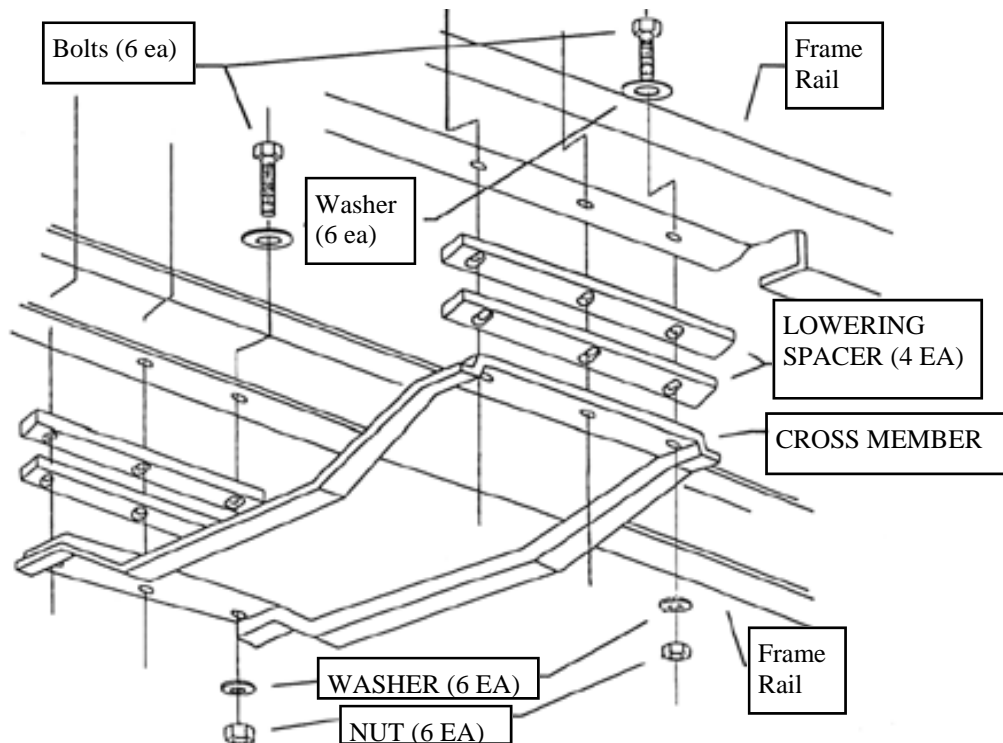

**** Channel type frame shown in above illustration - for box type frame, install bolt from bottom to existing nut above.**